

Tri-Kleen™ 500UV
Portable Air
Filtration Unit



Tri-Kleen™ 500UV Portable Air Filtration Unit

HEPA FILTRATION AND NEGATIVE PRESSURE MACHINE

Negative pressure rooms are used in healthcare settings to contain airborne contaminants within an infected occupant's room. The Tri-Kleen™ 500UV is a negative air machine with a built-in HEPA filtration system to provide the most effective mechanical filtration available.

This lightweight device creates negative pressure rooms for healthcare use, removing contaminated air from a closed controlled area. With HEPA filters contained within the unit, potentially dangerous particles are removed from the exhausted air at peak efficiency.



Tri-Kleen™ 500UV HEPA Filtration Machine

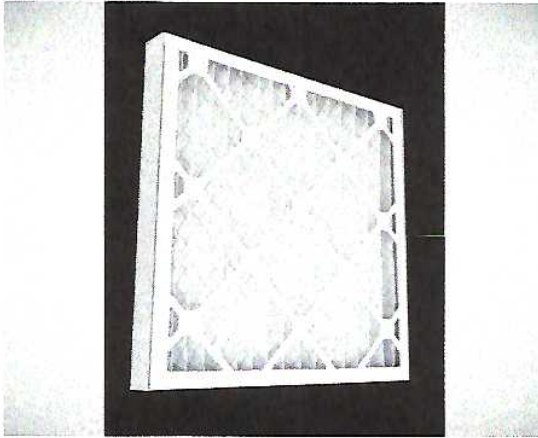

PRE-FILTER

TRI-PLEAT ULTRA is a MERV 9 pre-filter with initial resistance of 0.20" W.G. (50 PA) at the recommended airflow of 500 FPM (2.54 m/sec). Final resistance is 1.0" W.G. (249 PA).

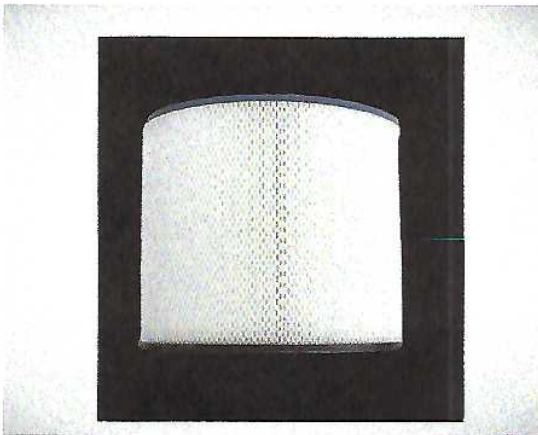

HEPA FILTER

The cylindrical HEPA filter has initial resistance of 1.20" – 1.24" w.g. at 500 CFM. The minimum initial efficiency is 99.97% on 0.3 micron size particles. The media is standard micro-glass HEPA Media.

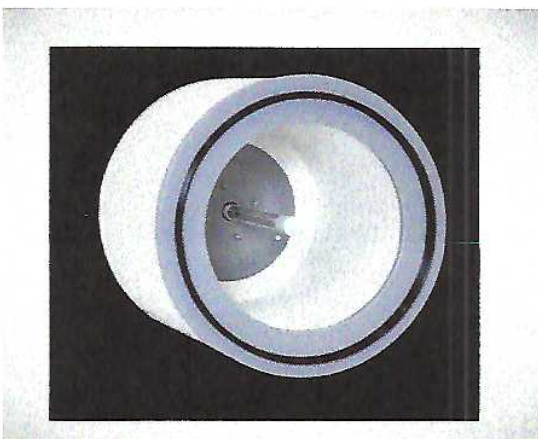

UV-C LIGHT

A 39W UV-C Germicidal Bulb is combined with a HEPA filter to increase the effectiveness of air cleaning from pathogens, such as bacteria and viruses.

Tri-Kleen™ 500UV Air Management

HIGHLY FLEXIBLE APPLICATION OPTIONS

The Tri-Kleen™ product gives public health officials and hospital staff the ability to turn a COVID-19 patient's room into a negative pressure environment, allowing field hospitals, temporary care units, nursing homes or ad-hoc locations the ability to maintain safety for patients and frontline staff.

NEGATIVE PRESSURE

To prevent particles from escaping from the room to be cleaned, it can be operated in negative pressure. Operation in negative pressure requires a solid technical ventilation setup. In this case, the incoming air must in any case be highly pure. We would be happy to support you with this request.

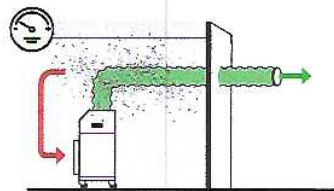

Application with negative pressure:
Tri-Kleen™ 500UV in negative pressure room with air hose leading outside

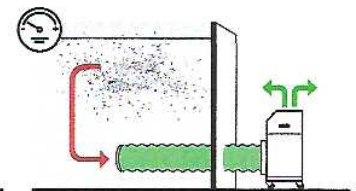

Application with negative pressure:
Tri-Kleen™ 500UV outside with air hose into the negative pressure room*

POSITIVE PRESSURE

Positive pressure rooms are used for applications where the room's interior must remain clean and will not be contaminated by polluted air, for example through airborne molecular contaminants or particles transported by microbes.

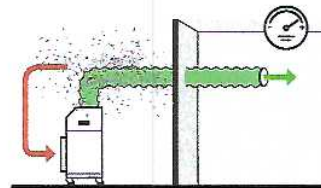

Application with positive pressure:
Tri-Kleen™ 500UV outside with air hose into the positive pressure room

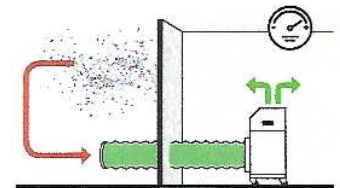

Application with positive pressure:
Tri-Kleen™ 500UV in positive pressure room with air hose leading outside*

CIRCULATING AIR

Closed-off rooms can be continuously cleaned of particles in circulation mode, which significantly improves the air quality.

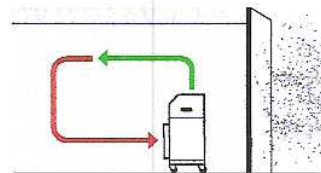

Application with circulating air:
air cleaning in closed areas using circulating air mode

*Tri-Kleen comes with one exhaust grille located on top of unit. Intake collar is not included

Tri-Kleen™ 500UV

Technical Information

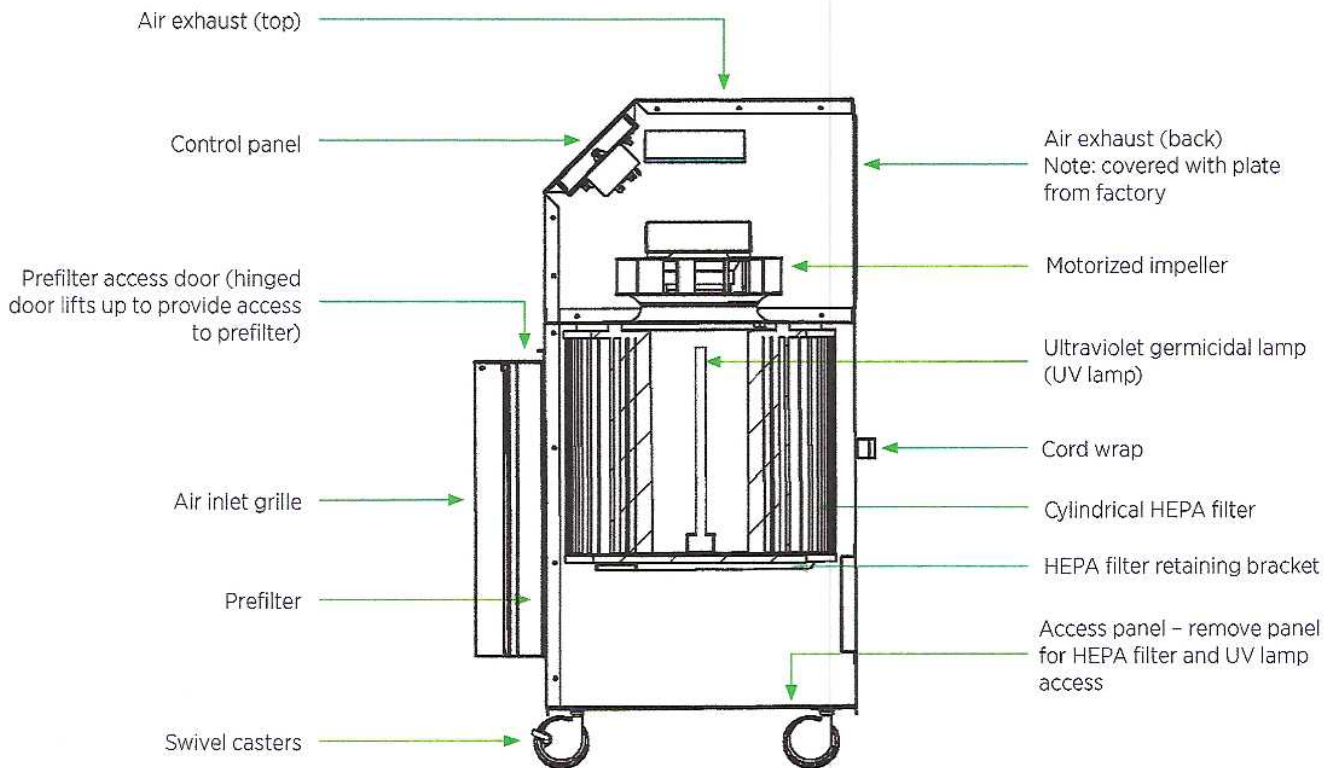

TRI-KLEEN™ 500UV FEATURES

Tri-Kleen™ 500UV has an optional exhaust collar that will allow for a flex duct to be attached and allow for the air to be exhausted to create a negative pressure in a space to allow for containment in a specific space.

OTHER FEATURES INCLUDE:

- HEPA filter
- Three speed settings, from 90 cfm to 500 cfm
- Quiet (52 dBA - 59 dBA)
- Filter loading indicator with audible alarm
- Smooth-rolling swivel casters with two front brakes
- LCD touch screen with state-of-the-art touch pad controls

Tri-Kleen™ 500UV

Technical Information

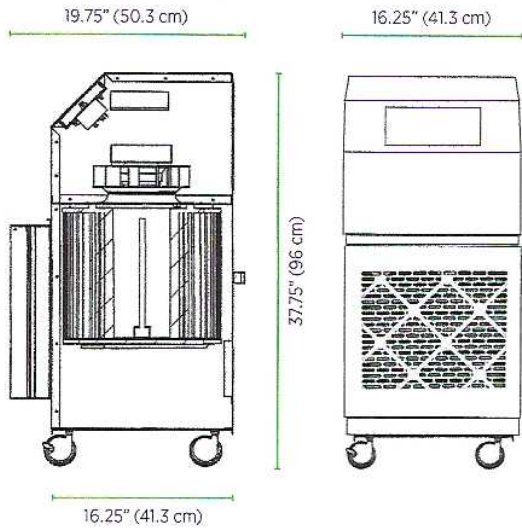

Feature	Specification
Net weight with filters	65 lbs (29.5 kg)
Shipping weight	83 lbs (37.6 kg)
Unit dimensions	W 16.25" x D 19.75" x H 37.75" (W 41.3 cm x D 50.3 cm x H 96 cm)
Shipping carton dimensions	W 20" x D 24" x H 44" (W 50.8 cm x D 61.0 cm x H 101.6 cm)
Power supply required	120 volts AC, 60 Hz, 15 amp circuit.
Max. current draw	2.5 amps
Automatic restart	Yes - the unit will automatically restart after temporary power interruption
Cabinet material	0.050" (1.3 mm) thick powder-coated white aluminum
Control panel	LCD touch screen controls
Circuit breaker	5-amp integrated circuit breaker
Filter loading indicator	Filter loading visual alarm on LCD touch screen with audible alarm (audible alarm can be enabled/disabled)
Air flow ratings	3 speed settings produce an air flow range of 90 CFM to 500 CFM (150 m ³ /h - 850 m ³ /h)
Power cord	10' (3 m) long, 14/3 AWG SJT hardwired power cord
Sound level	52 dBA - 59 dBA
Pre-filter	Standard prefilter: 2" (5 cm) deep pleated MERV 9 pre-filter.
HEPA filter	Cylindrical 99.97% efficient against 0.3 μm particles at max. air flow, with UV lamp integrated into the filter
Exhaust outlet	One exhaust grille located on top of unit. Exhaust grille dimensions: 12" x 8" (30.5 cm x 20.3 cm) Optional 8" nominal diameter (20.3 cm) exhaust collar included for connecting round ducting



Made in USA © MANN+HUMMEL GmbH

Tri-Dim Filter Corporation is committed to continual product development - all descriptions, specifications and performance data are subject to change without notice. Tri-Dim products are manufactured to exacting criteria - there can be a $\pm 5\%$ variance in filter performance.

Order Today!

Contact your local Tri-Dim sales representative or visit www.tridim.com

**MANN+
HUMMEL**



TRIDIM
A MANN+HUMMEL Company

Tel: 800-458-9835
info@tridim.com

tridim.com
mann-hummel.com
2100-4 0420 © MANN+HUMMEL GmbH